



DAVINCI TECHNICAL DATA GUIDE

AUTOMATIC CONTROL VALVES

AIR RELEASE VALVES WITH CLOSURE

Ref. 173A-NIJ / PN 10-16



Application

Clean and pre-treated water
Fire protection systems
Irrigation networks
Cooling water circuits
HVAC installations

Approvals/Standards

Mounting flange: PN10/16 EN 1092-2, ISO 7005-2.
Pressure Tests acc. to EN 12266-1 Rate A. GB/T13927-1992
Pressure Tests: Seat: 1,1 x PN
EU directive 2014/68/EU:
Products excluded, article 1, § 2b up to DN200.

Certifications

CE, WRAS

Range

DN50-200, PN10-16



GENERAL CHARACTERISTICS

Sizes DN50 to DN200.
Closing valve included.
Strong floats.
WRAS certificate for drinking water (rubber and paint).

WORKING CONDITIONS

Pressure ratings: Up to 1.0 Mpa and 1.6 Mpa.
Working temperature: -10°C + 100°C.
Flow media: Clean water.

| N° | ITEM | MATERIAL |
|----|-------------------|----------------------|
| 1 | Body | GJS500-7 |
| 2 | Left bonnet | GJS500-7 |
| 3 | Orifice cover | Carbon steel |
| 4 | Stem | AISI 420 |
| 5 | O-ring | EPDM |
| 6 | Anti dust ring | EPDM |
| 7 | Disc | GJS500-7 + EPDM |
| 8 | Gland | Brass |
| 9 | Locating ring | Brass |
| 10 | Left bolt | Carbon steel |
| 11 | Right bolt | Carbon steel |
| 12 | Right bonnet | GJS500-7 |
| 13 | Sear ring | EPDM |
| 14 | Gasket | EPDM |
| 15 | Ball | Wood ball + NBR/EPDM |
| | RAL 5015 Painting | Epoxy 250 µm |

Components may be replaced with materials of equivalent or superior grade without prior notice, in accordance with our continuous improvement policy.

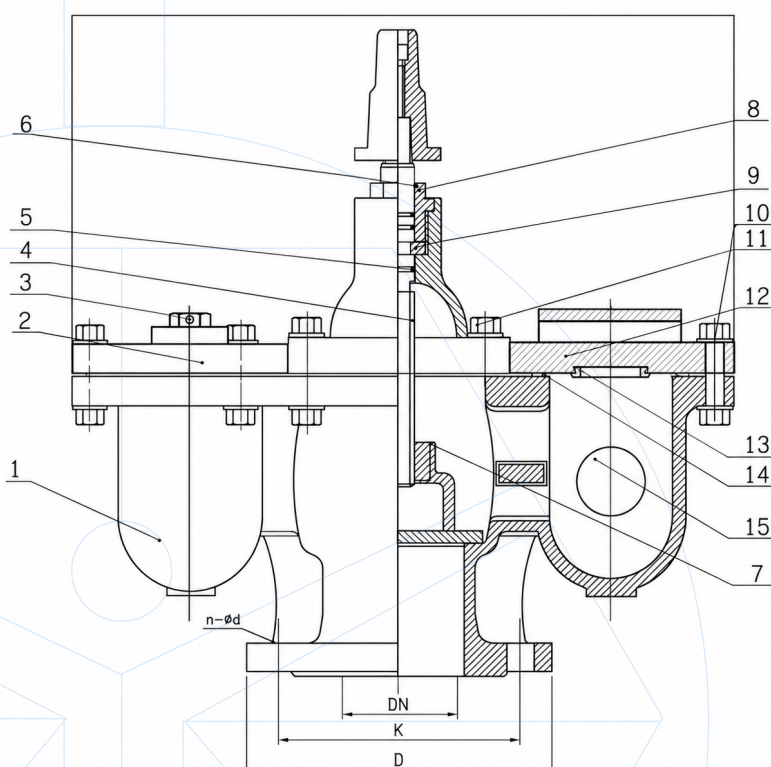

| DN | H | L | K | | D | | n-d | | Weight (kg) |
|-----|-----|-----|------|------|------|------|------|-------|-------------|
| | | | PN10 | PN16 | PN10 | PN16 | PN10 | PN16 | |
| 50 | 225 | 370 | 125 | | 165 | | 4-19 | | 15 |
| 65 | 230 | 370 | 145 | | 185 | | 4-19 | | 18 |
| 80 | 250 | 410 | 160 | | 200 | | 8-19 | | 23,5 |
| 100 | 265 | 430 | 180 | | 220 | | 8-19 | | 26,5 |
| 150 | 360 | 560 | 240 | | 285 | | 8-23 | | 57,6 |
| 200 | 440 | 720 | 295 | | 340 | | 8-23 | 12-23 | 127 |



CONTACT US

DAVINCI VALVES ORDER REQUEST

Ref. 173A-NIJ / PN 10-16



Head Office CHENGDU

Room 3208 Unit 1 Building 1,
No. 6 Zhiqian Section, Dongda Street
Jinjiang District, Chengdu, Sichuan
CHINA

+86 17340168233 +86 19302892712
valves@davincivalves.com

Europe Office MADRID
SPAIN
zuzana@davincivalves.com

WEBSITE

davincivalves.com

YOUR QUALITY WATER PROJECTS PARTNER
For professionals who look for more.